

SANDBLASTERS

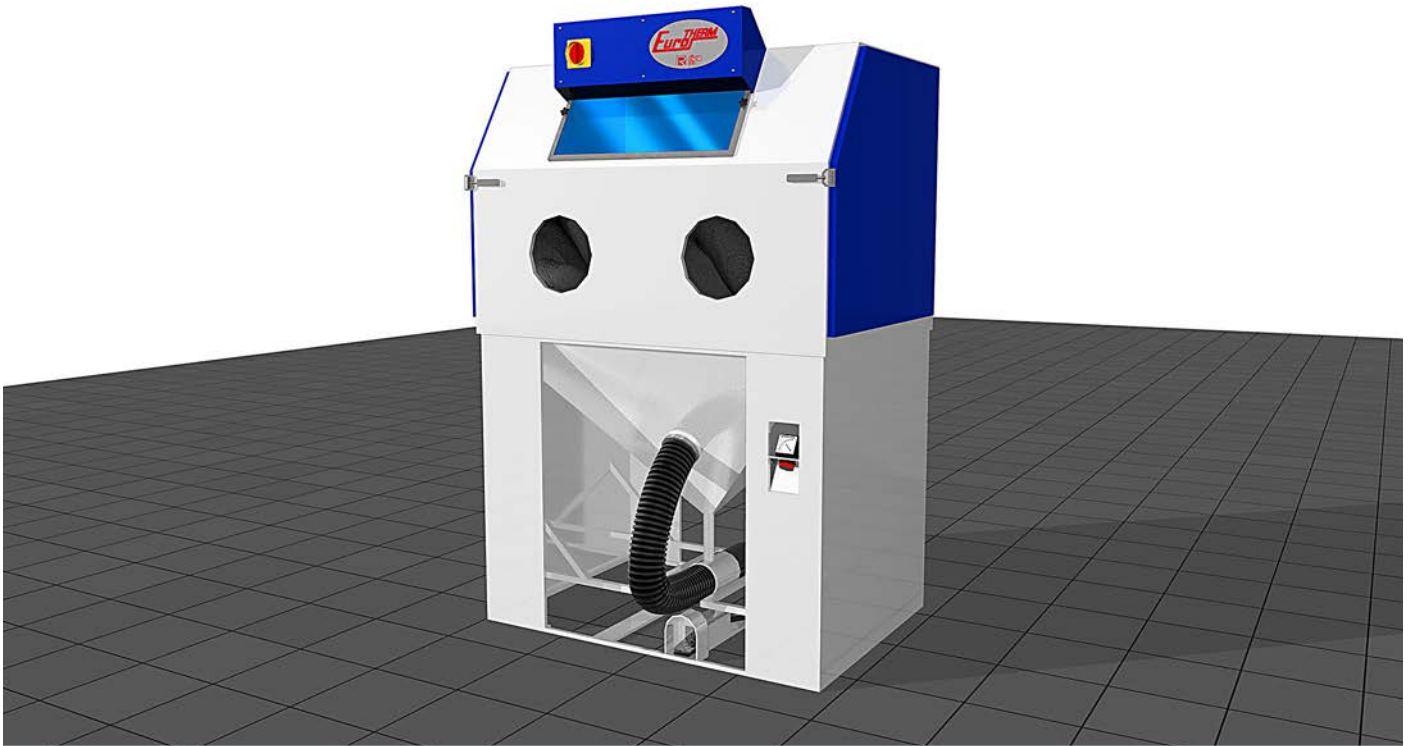

Compact suction sandblasters with rotary table



Basic version



Back view



"TE" version with extractable rotary table

OPTIONAL ACCESSORIES

Filter unit with paper or polyester cartridges and automatic compressed air cleaning system
Conversion kit for pressurized mod

NOTES

Complete cyclone separator to remove dust from the cabin and select and recover the grit
Blast gun with \varnothing 8 mm tungsten carbide nozzle
Blow and cleaning gun
Internal rotary table with 500 kg load capacity
Side doors for access to the cabin with safety endswitches
Airtight lamps with 20 x 20 tubes for inside lighting
Footswitch for start and stop of blasting process
Predisposition for filter unit
Control panel complying to CE Norms
Reinforced gloves
Delivered as complete assembly
Made of painted steel sheet
Technical characteristics and dimensions are approximate and subject to changes for improvements or updates without notice

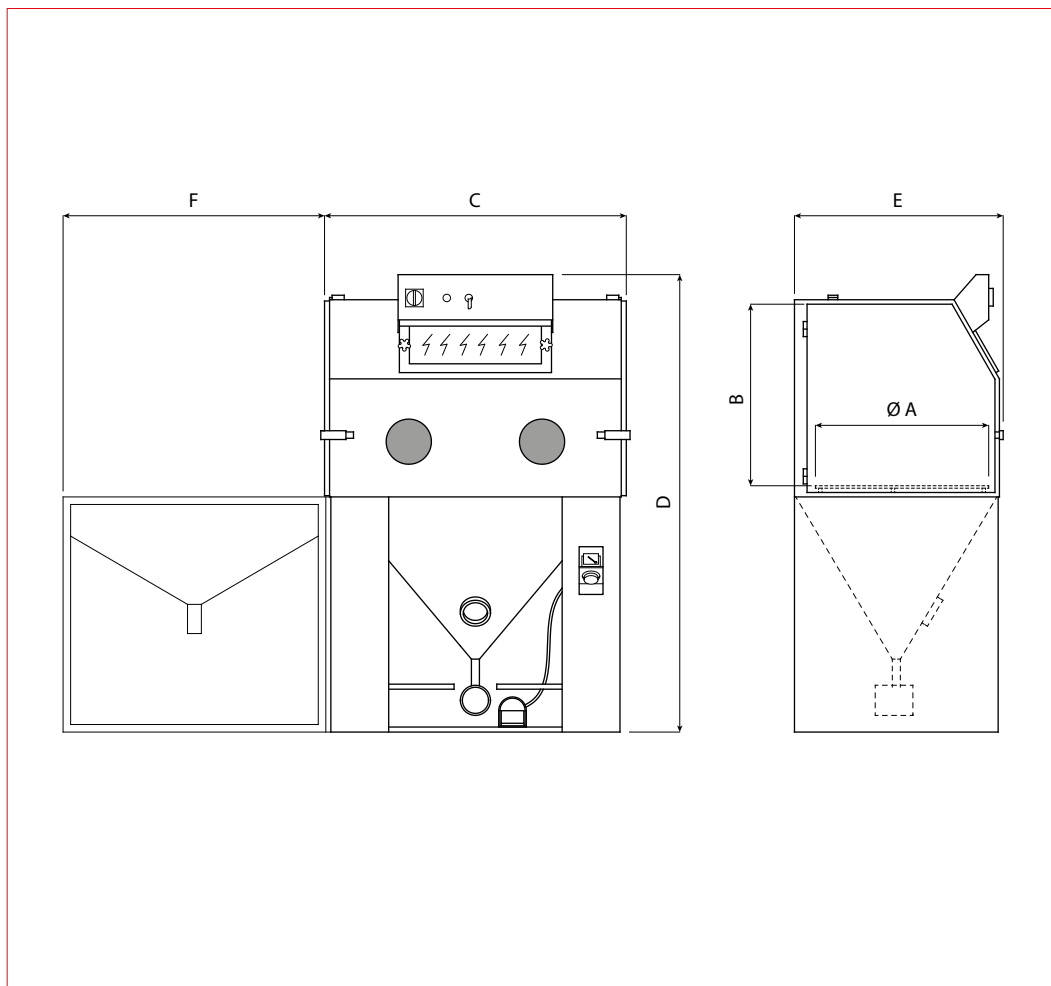

DESCRIPTION OF EQUIPMENT

Model	Useful dimensions		External dimensions			
	Ø A	B	C	D	E	F
Euro CSA1	700	750	1200	1800	850	/
Euro CSA2 TE	900	900	1200	1900	1100	1000
Euro CSA3	950	900	1600	1900	1200	/
Euro CSA3 TE	900	900	1600	2050	1300	1400

TECHNICAL DATA

Model	Compressed air consumption	Electric power	Power supply	Weight	Internal rotary table	Extractable rotary table
Euro CSA1	780	0,55	400V 50Hz	305	●	○
Euro CSA2 TE	780	0,55	400V 50Hz	450	●	●
Euro CSA3	780	0,55	400V 50Hz	415	●	○
Euro CSA3 TE	780	0,55	400V 50Hz	510	●	●