

## PAINTING BOOTHS WITH DRY FILTRATION

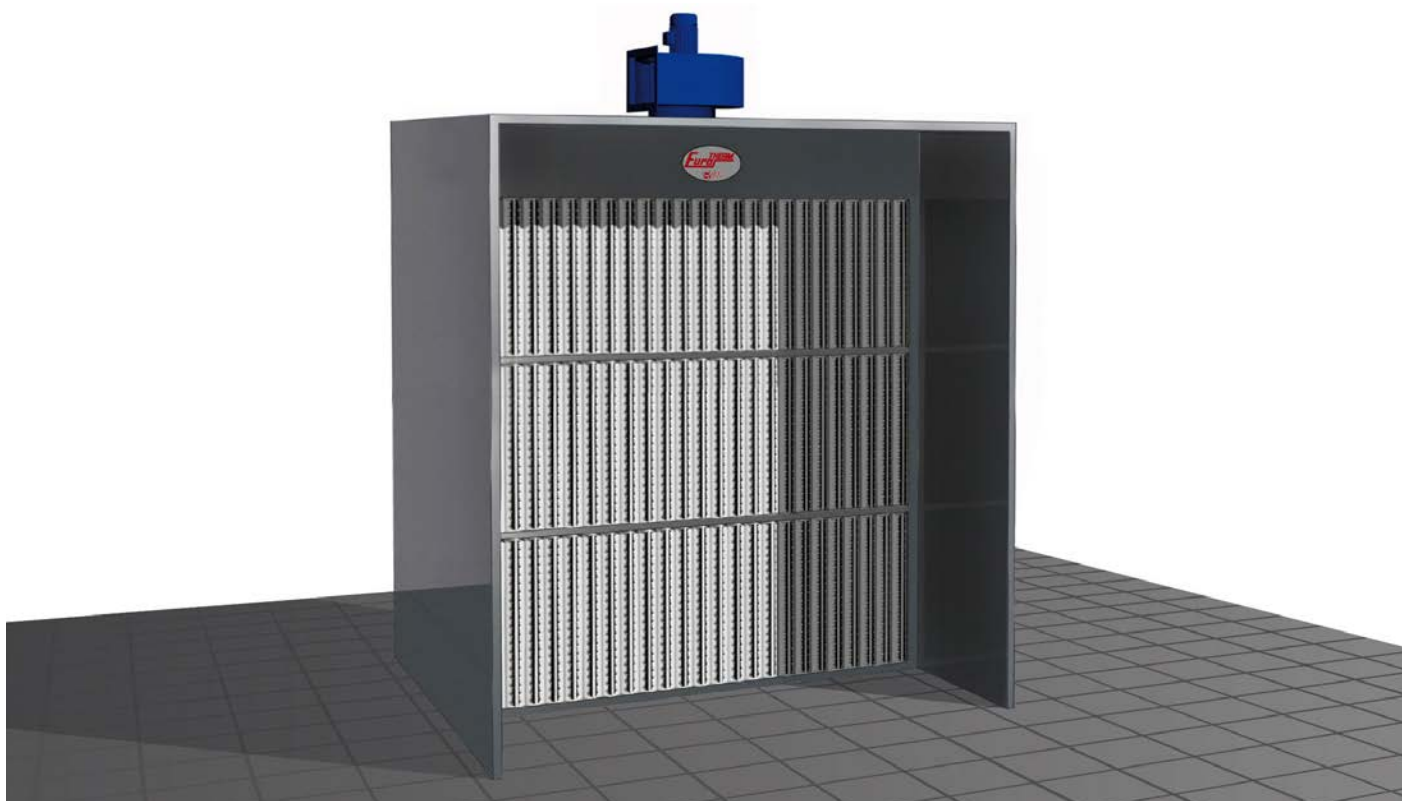

Professional grade with double filter stage as standard

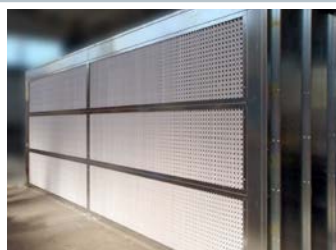

Standard extraction wall



Sidewalls and roof extension



For large components



Customized solutions

### OPTIONAL ACCESSORIES

- Extraction ducts with silencers
- Extension of sidewalls and roof with 1000mm module
- Neon light IP 65, 1500 mm length with 2 x 58 W neon lamps
- Electric control board CE CRAM
- Wall holding device for spray gun with automatic fan switch-off
- Painted extraction wall

### NOTES

- Spark proof fan
- Second filtration with fiber-glass filters
- Differential manometer for indicating filter replacement
- Supplied as assembly kit
- Construction of extraction wall of galvanized steel sheet
- Technical characteristics and dimensions are given as indication and can be changed for improvement or update without notice

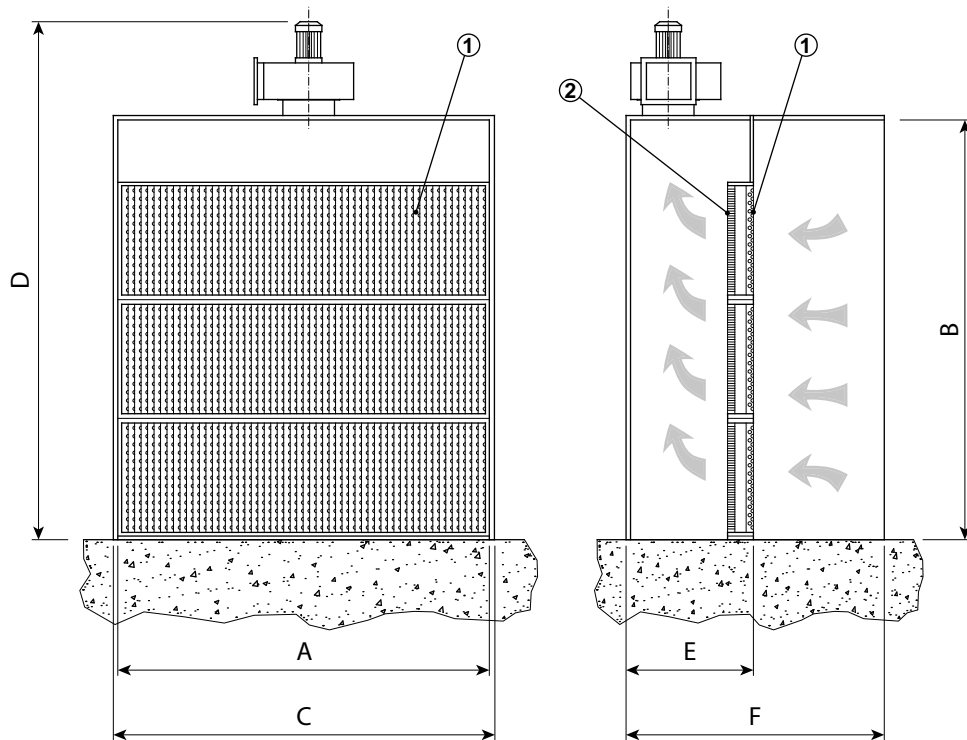

- ① FILTER PAPER
- ② FILTERS IN FIBER-GLASS

## DESCRIPTION OF EQUIPMENT

Model	Useful dimensions		Overall dimensions			
	A	B	C	D	E	F
Eurodry 1,5 H	1.500	3.120	1.580	3.943	790	1.790
Eurodry 2 H	2.000	3.120	2.080	3.990	790	1.790
Eurodry 2,5 H	2.500	3.120	2.580	3.990	790	1.790
Eurodry 3 H	3.000	3.120	3.080	4.101	790	1.790
Eurodry 4 H	4.000	3.120	4.080	3.943	790	1.790
Eurodry 5 H	5.000	3.120	5.080	3.990	790	1.790

## TECHNICAL DATA

Model	Air capacity	Fans	Electrical power	Second filtration filters
	m <sup>3</sup> /h	nb	kW	nb
Eurodry 1,5 H	8.500	1	2,2	9
Eurodry 2 H	11.500	1	3	12
Eurodry 2,5 H	14.000	1	4	15
Eurodry 3 H	17.000	1	5,5	18
Eurodry 4 H	22.500	2	2,2 + 2,2	24
Eurodry 5 H	28.000	2	4 + 4	30