

PAINTING BOOTHS WITH DRY FILTRATION



“Mini” range with simple filtration



Rotating part carrier



Mini 1



Mini 2



Second filtration



Painted version

OPTIONAL ACCESSORIES

- Second filtration with fiber-glass filters
- Extraction ducts with silencers
- Neon light IP 65, 600 mm length with 1 x 18 W neon lamp
- Neon light IP 65, 1200 mm length with 2 x 36 W neon lamps
- Electric control board CE CRAM
- Wall holding device for spray gun with automatic fan switch-off
- Painting
- Rotating part carrier

NOTES

- Spark proof fan
- Differential manometer to signal filters replacement
- Supplied as assembly kit
- Galvanized steel sheet construction
- Technical characteristics and dimensions are given as indication and can be changed for improvement or update without notice

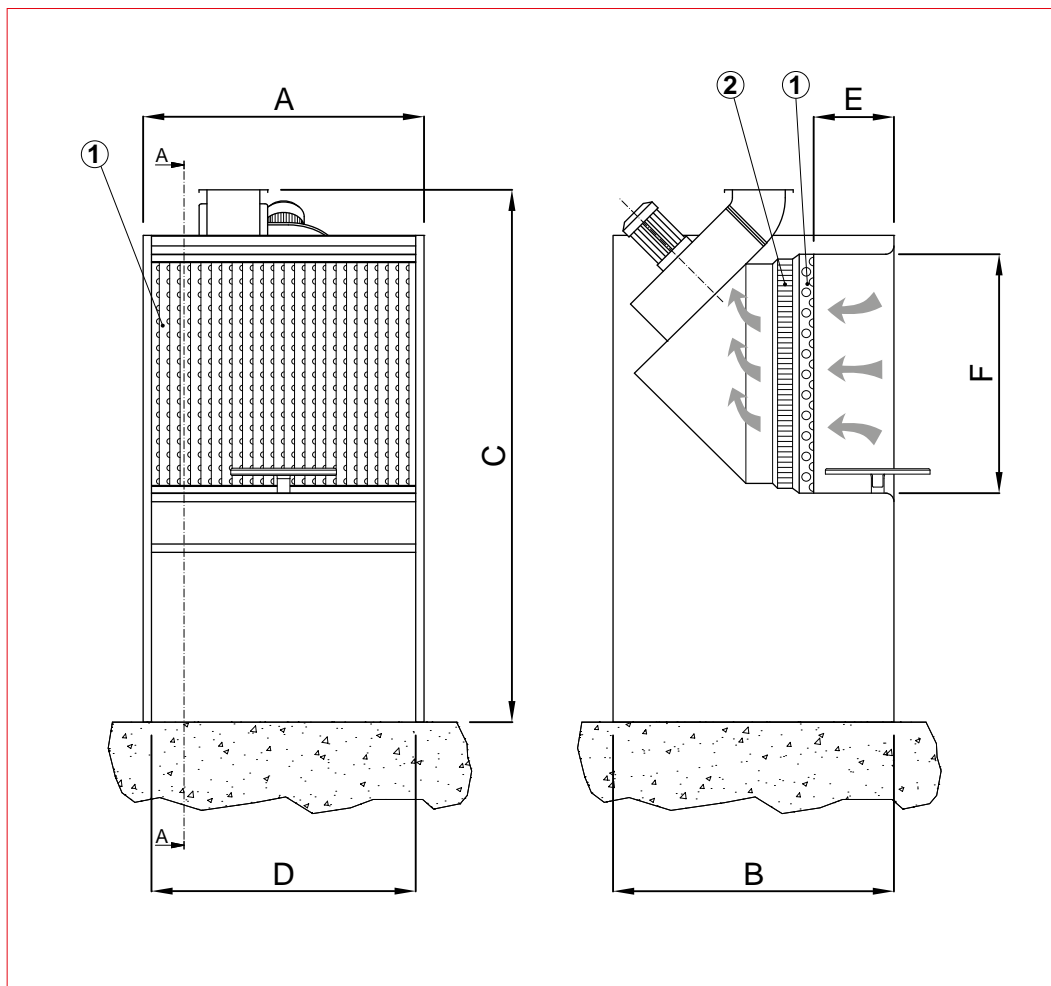

- ① FILTER PAPER
- ② SECOND FILTRATION OPTIONAL

DESCRIPTION OF EQUIPMENT

Model	Overall dimensions			Useful dimensions		
	A	B	C	D	E	F
Mini 1	1.060	1.060	2.000	1.000	300	905
Mini 2	2.060	1.060	2.000	2.000	300	905

TECHNICAL DATA

Model	Air capacity	Fans	Electrical power
	m ³ /h	nb	kW
Mini 1	2.000	1	0,55
Mini 2	4.000	1	1,5