



# Powder coating booths

**EUROTHERM**  
SINCE 1958

PAINTING INSTALLATIONS





# Powder coating booths

We create **paint booths** suitable for use with powder paints to **satisfy any requirement of your company.**

Our booths are the **ideal environment in which to apply the powder to the products**, the constant air flow avoids saturation of the dust in the work environment and the high filtration capacity of the extracted air avoids the outward dispersion of dust. According to the needs of your company, **Eurotherm** technicians will guide you towards the best choice to guarantee you quality, fast and flexible painting.

## MANUAL POWDER COATING BOOTH WITH VERTICAL AIR FLOW

The vertical air flow powder coating booths are the most professional ones and are equipped with:

- Vertical filtered air flow.
- Closed painting booth with entry door.
- Filter roof.
- Grated floor.
- Floor extraction through hoppers connected to the external filter unit.

In this way, the air flow in transit is more even and the incoming air cleaner, compared to horizontal flow booths, ensuring optimal and constant working environment conditions over time.

## MANUAL POWDER COATING BOOTH WITH HORIZONTAL AIR FLOW

This is our **basic solution but with exceptional value for money** and which allows the performance of powder coating in a safe environment.

The air is extracted directly from the front opening of the booth through the suction wall located at the rear of the booth.

## AUTOMATIC POWDER COATING BOOTHS

They satisfy the requirements of companies that need to paint numerous batches consisting of many small or medium-sized pieces with a high production rate.

It is **the most suitable solution** to be inserted **in partially or fully automatic systems.**

## POWDER COATING BOOTH

From simple extraction walls and complete vertical air flow booths for manual application to automatic PVC booths with cyclones for rapid colour changes.

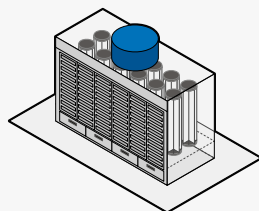

➤ **Extraction wall** with filter cartridges

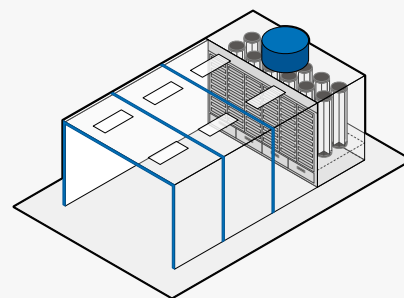

➤ **Manual painting booth** with walls and roof made of pre-insulated painted panels and lights



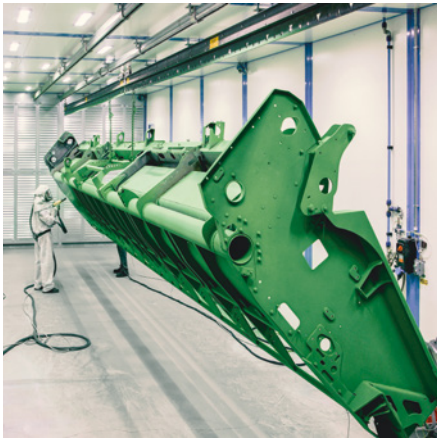

➤ Horizontal air flow powder coating booths

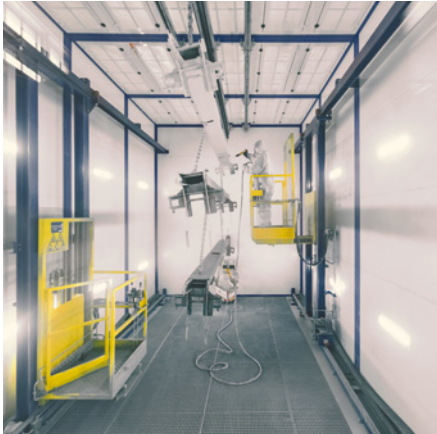

➤ Vertical air flow powder coating booths



➤ Automatic PVC powder coating booths with cyclone for quick colour change

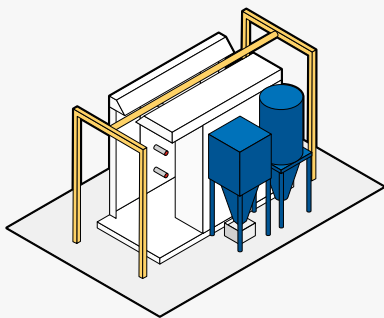

➤ Automatic recovery painting booth with filter group and cyclon

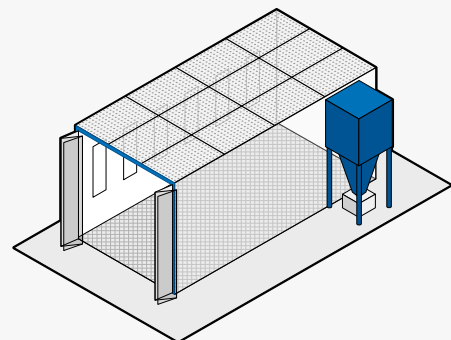

➤ Vertical air flow painting booth with filtered air inlet roof and floor extraction



## PAINTING INSTALLATIONS

### ITALY | Turin

---

#### **Eurotherm S.p.A.**

Turin Headquarter  
Via Pisa, 78  
10088 Volpiano (TO)  
T. +39 011 98 23 500  
M. [info@eurotherm.eu](mailto:info@eurotherm.eu)

### ITALY | Verona

---

#### **Eurotherm S.p.A.**

Verona Office  
Viale Delle Nazioni, 10  
37135 Verona

### FRANCE

---

#### **Eurotherm France S.A.S.**

71 Rue de Malacombe  
38070 Saint Quentin Fallavier  
T. +33 6 76 72 48 65  
M. [france@eurotherm.eu](mailto:france@eurotherm.eu)

### GERMANY - AUSTRIA - SWITZERLAND

---

#### **Eurotherm Oberflächentechnik GmbH**

Schulweg 6  
D-72488 Sigmaringen  
T. +49 (0) 7571/92795-10  
F. +49 (0) 7571/92795-99  
M. [germany@eurotherm.eu](mailto:germany@eurotherm.eu)

Since 1958 we have been manufacturing customised systems to meet the painting needs of any company: from small businesses to large industries.

For the Italian and international market we design, build and install painting systems, overseeing every phase of the industrial process.

From pre-treatment operations, such as washing and shot blasting, to the final finishing process: **the Eurotherm systems apply the most efficient and technological processes, to ensure a constant high-level result.**



SHOT  
BLASTING



WASHING



LIQUID  
PAINTING



POWDER  
PAINTING

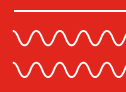

CURING